

JETE

USER MANUAL

HEADPHONE SV1



Please read the instructions carefully
before using the product.

Product Introduction :

Thank you for purchasing JETE products. For optimal and safe performance, it is expected to read the instructions carefully before using this product.

Content Package :



SV1

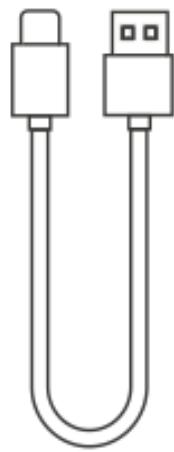

Charging Cable



Dongle Receiver



User Manual

Description Structure Product :

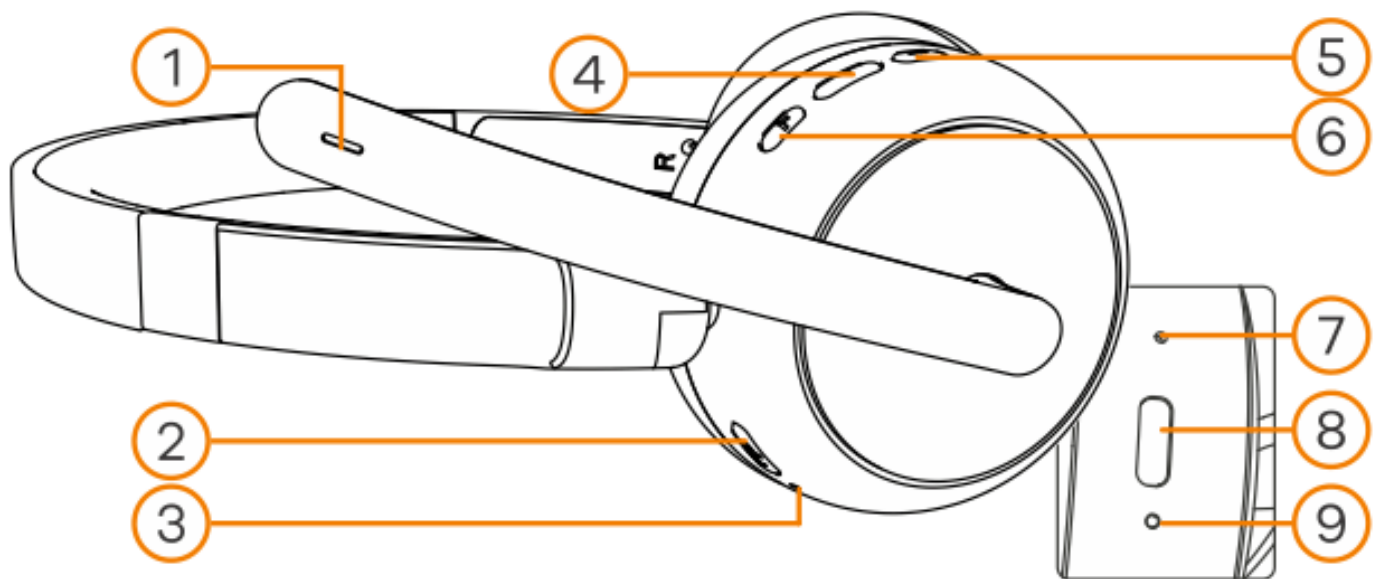

- | | | |
|-------------------------|-----------------|--------------------|
| 1. Microphone 1 | 4. MFB | 8. USB-C Port |
| 2. Mute Button | 5. (-) Button | 9. Indicator Light |
| 3. Light Indicator Mute | 6. (+) Button | |
| | 7. Microphone 2 | |

Tips:

- Regular use of the headphones is the easiest way to maintain them.
- It is recommended to listen to music at a moderate volume to protect your hearing.

How to Use :

How to Turn On the Headphones :

Press and hold the MFB button for 3 seconds. The indicator light will flash blue and red, indicating the headphones are ready to pair.

How to Turn Off the Headphones :

Press and hold the MFB button for 3 seconds. The indicator light will flash red, indicating the headphones are powered off.

How to Pair the Headphones :

Using Bluetooth

1. Turn on the headphones. The indicator light will flash blue and red, indicating the headphones are in pairing mode.
2. Turn on Bluetooth on your device.
3. Enable the search function and select "JETE-SV1".
4. Once connected, a voice prompt will be heard and the indicator light will turn off.

Using Adapter Dongle Receiver

1. Turn on the headphones. The indicator light will flash blue and red.
2. Connect the adapter dongle receiver to the device.
3. Once connected, the indicator light will flash blue.

Note:

- The headphones have a memory function that will automatically reconnect to the previously paired device when turned on.

- The connection will be disconnected when you move out of the headphone range (10 m) and will automatically reconnect when you return within range within 5 minutes.

How to Answer a Call:

Press the MFB once to answer an incoming call (Bluetooth mode and adapter mode).

Tip : Some device types can only answer calls through the device itself. Please follow the instructions on your device.

How to End a Call:

- Press the MFB once to end a call (Bluetooth mode).
- Press the MFB twice to end a call (adapter mode).

How to Reject a Call:

- Press and hold the MFB button for 2 seconds when there is an incoming call (Bluetooth mode).
- Press the MFB button twice to reject the call (adapter mode).

How to Redial the Last Number:

Press the MFB button twice to call the last dialed number (Bluetooth mode).

How to Activate Voice Assistant:

Press the MFB button three times to activate the voice assistant.

Note:

In adapter mode, there may be slight differences in functions depending on the device version used.

How to Change Mode:

Press the Mute button twice to switch between Bluetooth mode and adapter mode.

How to Mute / Activate the Microphone:

Press the Mute button once to turn the microphone off or on.

How to Play Music :

- Press the MFB button once to play or pause the music.
- Press the (-) button once to decrease the volume.
- Press the (+) button once to increase the volume.
- Press and hold the (-) button for 2 seconds to play the previous track.
- Press and hold the (+) button for 2 seconds to play the next track.

How to Charge :

- Use a USB-C charging cable to charge the device.
- For first-time use, charge the headphones for 2 hours.
- During the charging process, the indicator light will turn on and will automatically turn off once charging is complete.

Product Specification :

Bluetooth Version	: V6.0
Usage Time	: 35 hours
Talk Time	: 26 hours
Standby Time	: 46 hours
Impedance	: $32 \pm 15\% \Omega$
Speaker Size	: 40 mm
Battery Capacity	: 400 mAh
Audio Codec	: SBC & AAC
Charging Time	: 2 hours
Sensitivity	: 115 dB \pm 3 dB
Microphone Sensitivity	: -33 dB
Frequency	: 20 Hz – 20 kHz
Input	: DC 5V / 0.3A
Wireless Range	: 10 m (Without obstacles)

JETE

**WARRANTY CARD and
USER MANUAL**

HEADPHONE SV1



e-Usermanual

IMPORTIR

PT. DORAN SUKSES INDONESIA

Jl. Lebak Jaya 2 Tengah No. 2, Surabaya

CUSTOMER SERVICE



081217393609



jete.id



jeteindonesia



jeteindonesia



jeteindonesia

Maintenance :

Please read the following recommendations before using JETE

- Avoid exposing the device to water vapor or humid places. This can affect the internal circuit.
- Do not use cleaning solutions to clean the device.
- Do not expose the device to extreme heat or cold, as this can damage the device or change certain plastic parts.
- Avoid exposing the device to sharp objects, as this can cause scratches and damage.
- Do not disassemble or modify the device.
- Do not drop the device, as this can damage the circuitry.
- Always store the device at room temperature.

How to Warranty Claim JETE Product :

1. All warranty claims can be made at the list of Authorized Outlets listed on the warranty card.
2. Buyers can come to an authorized Outlet or contact Customer Service +62812-1739-3609 if they want to exchange the product online.
3. All expedition shipping costs / product postage are borne by the buyer.
4. When claiming the warranty, the buyer is MANDATORY to show the completeness of the warranty:
 - A purchase receipt that clearly states the name of the outlet and the date of the transaction.
 - The product must still be within the specified warranty period.
 - Warranty card that has been filled out.
 - Box / Packing Product.
5. Please inform the constraints / product damage that occurs to our staff.
6. WARRANTY DOES NOT APPLY if USER DAMAGE is found, namely:
 - BROKEN, CRACKED, BURNED, DROPPED, MODIFIED BY YOURSELF, SUBMERGED IN WATER.
7. If there are problems during warranty claims or other questions, please contact Customer Service +62812-1739-3609

Terms and Conditions of Warranty :

1. This warranty is valid for 2 years for original JETE products.
2. This warranty is valid for the warranty period stated on the product packaging since the date of sale.
3. During the warranty period, the user is exempt from any replacement costs that may occur.
4. The user must show the warranty card and purchase receipt when applying for a warranty.
5. The warranty applies to functional damage:
 - Disfunction.
 - Audio not detected.
 - Indicator off.
 - Battery damage.
6. This warranty DOES NOT APPLY if:
 - PRODUCT IS BROKEN, CRACKED, BURNED, FALLEN,
 - MODIFIED YOURSELF, SOAKED IN WATER.
 - Supporting accessories such as: cables, adapters, etc.
 - Abnormal use, not stored properly, natural disasters, modified, or anything intentionally.
 - The product has been repaired by a third party.
 - The data is not filled in completely by the seller and buyer.
 - Damage caused by user error.
 - The product warranty period has expired.

**2 YEARS
WARRANTY**

**NEW REPLACEMENT
FOR ANY FAULTS *T&C**



Contact Us

JETE WARRANTY POINTS

