

JETE

**WARRANTY CARD and
USER MANUAL**

SMART REMOTE IR1+RF



e-Usermanual

IMPORTIR

PT. DORAN SUKSES INDONESIA

Jl. Lebak Jaya 2 Tengah No. 2, Surabaya

CUSTOMER SERVICE

 **081217393609**

 jete.id  [jeteindonesia](https://www.instagram.com/jeteindonesia)

 [jeteindonesia](https://www.facebook.com/jeteindonesia)  [jeteindonesia](https://www.twitter.com/jeteindonesia)

JETE

USER MANUAL

SMART REMOTE IR1+RF

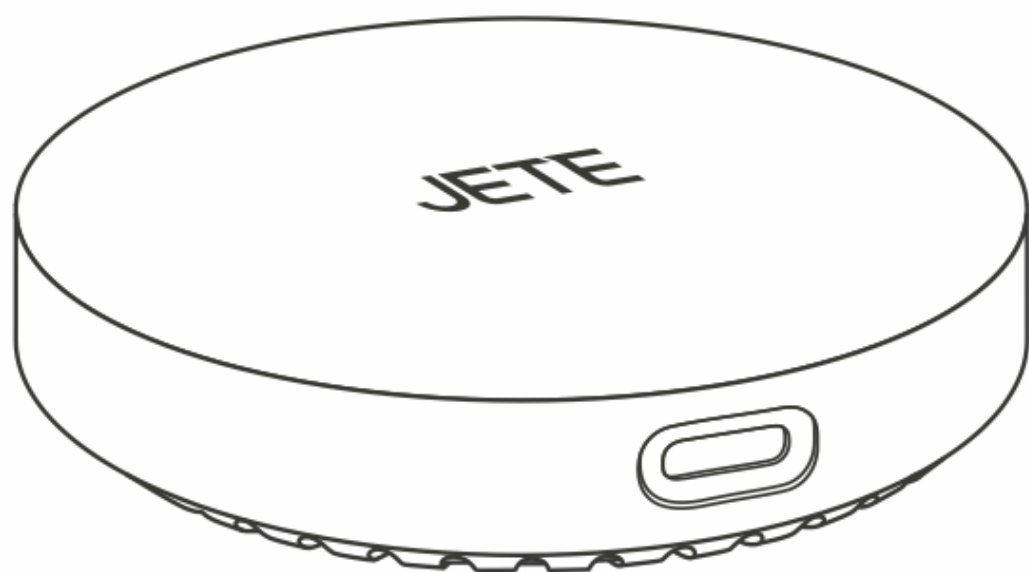

Please read the instructions carefully
before using the product

Product Introduction :

Thank you for purchasing JETE products. For optimal and safe performance, it is expected to read the instructions carefully before using this product.

Content Package :

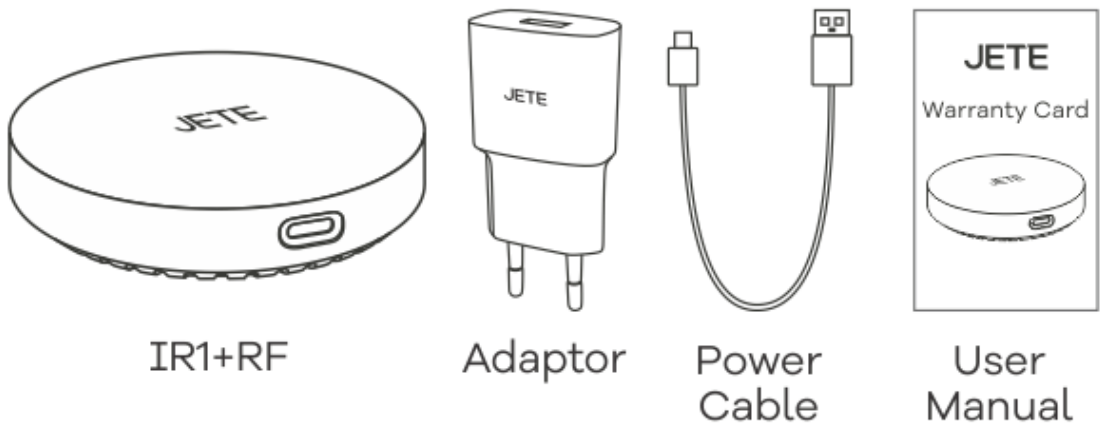

Description Structure Product :

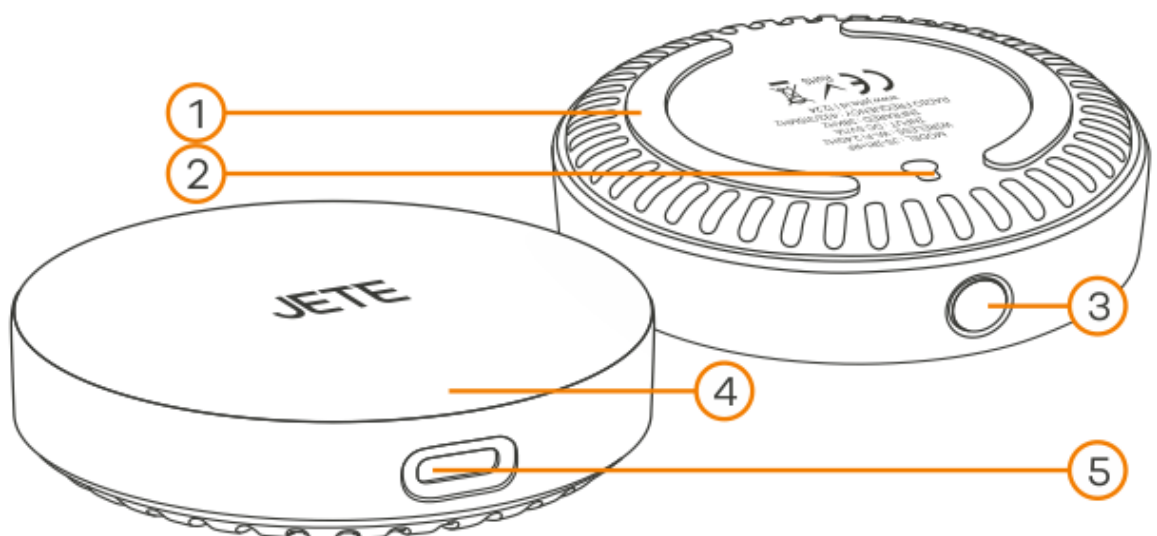

- | | | |
|-----------------|------------------|----------------|
| 1. Anti-Slip | 3. Reset Button | 5. Port Type-C |
| 2. Hanging Hole | 4. Indicator LED | |

How to Install and Register Applications:

QR Aplikasi
"JETE SMART"



App Store: JETE SMART



Google Play: JETE SMART



1. Go to the Play Store or App Store, or you can scan the QR code on the packaging.
2. Download and install the "JETE SMART" application.
3. First-time users must register first.
4. Select Sign Up to register.
5. Enter your email and country of residence.
6. Enter the verification code sent to your email address.
7. Enter your password.

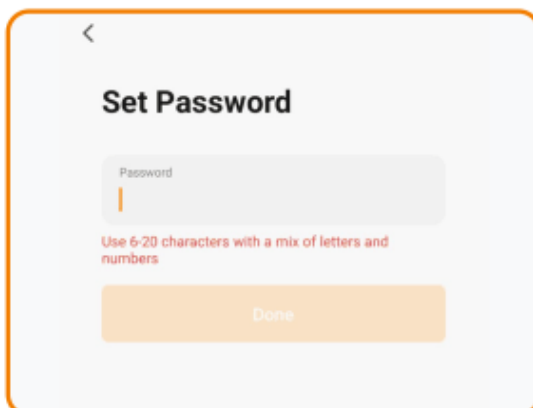
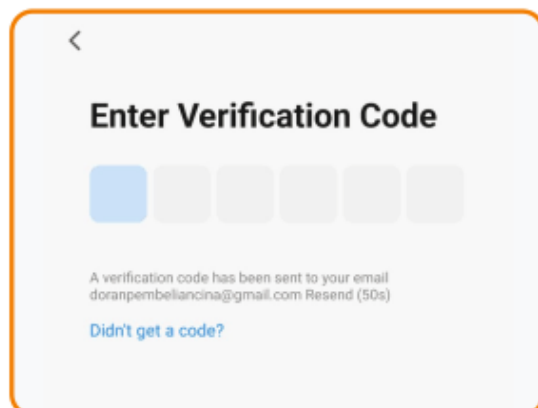
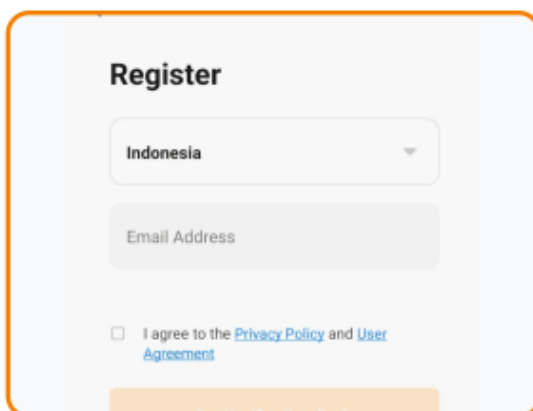
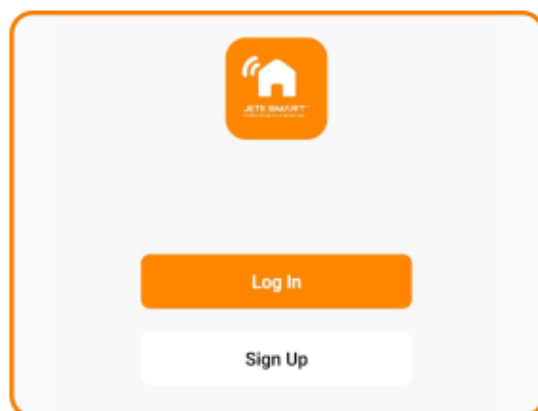

Note:

JETE SMART is an application designed to simplify the control of your JETE Smart Home devices.

How to Connect with Smartphone :

1. Open the JETE SMART application.
2. Select the "+" icon and select Add Device.

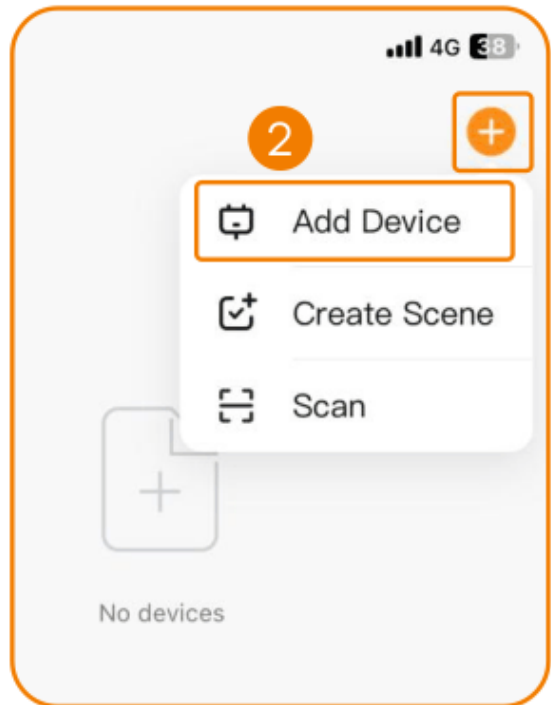
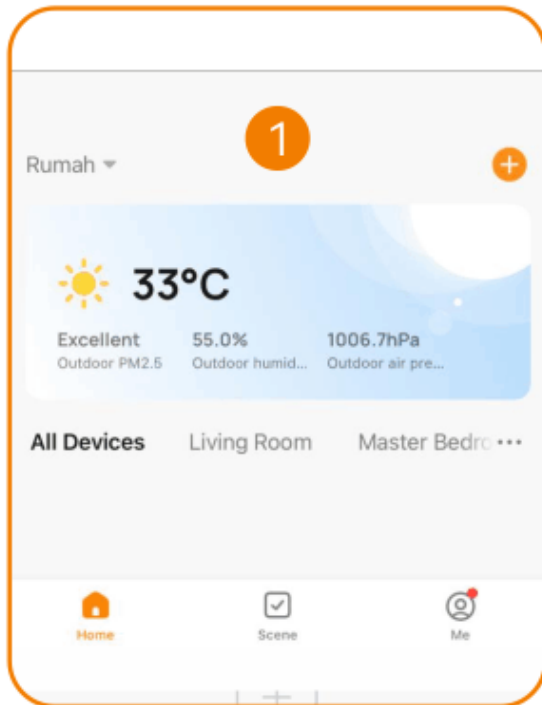

3. Select the JETE-IR1+RF device.
4. Enter the WIFI password.

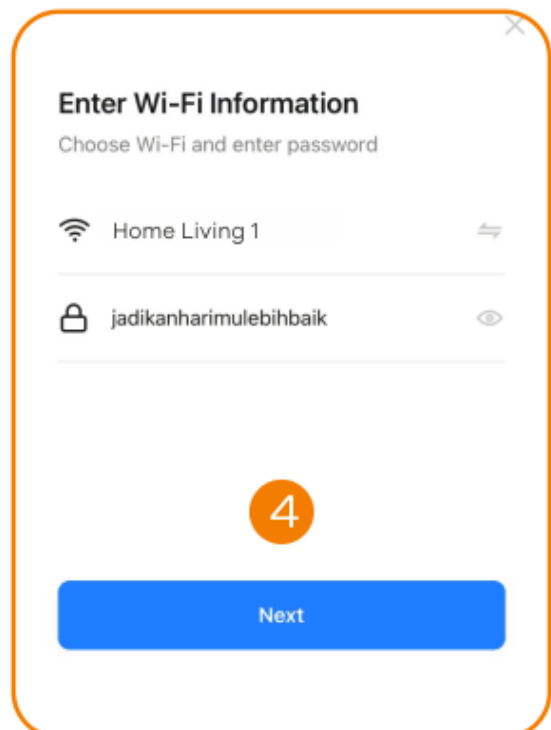
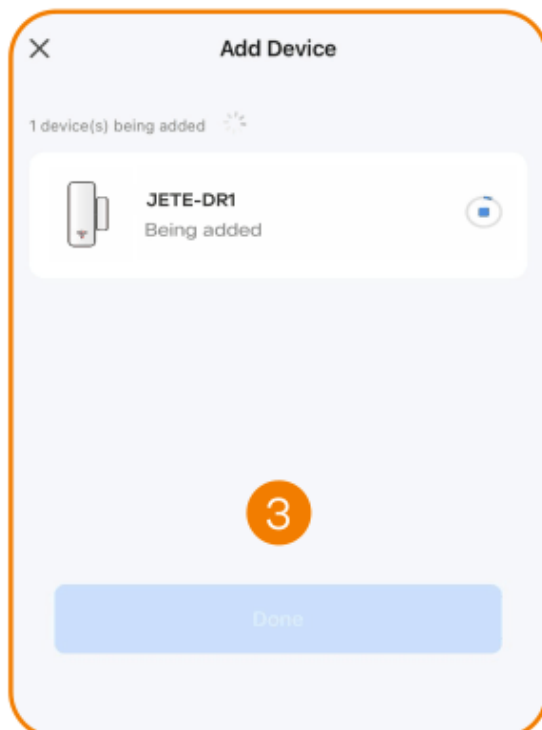

5. The sound indicator will sound and the light will stay on indicating that JETE-IR1+RF is successfully connected.

Adding IR Devices :

1. Select the Infrared Remote Box device
2. Press the "Add" icon.
3. Select the device you want to connect.
4. Press the icon that appears in the middle.
5. If the device does not react, press "Another One"
6. If the device reacts, press "Can Control".

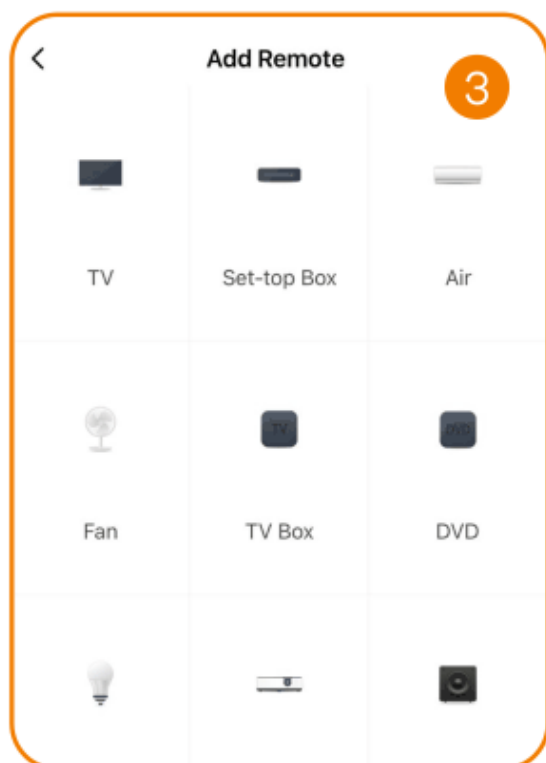
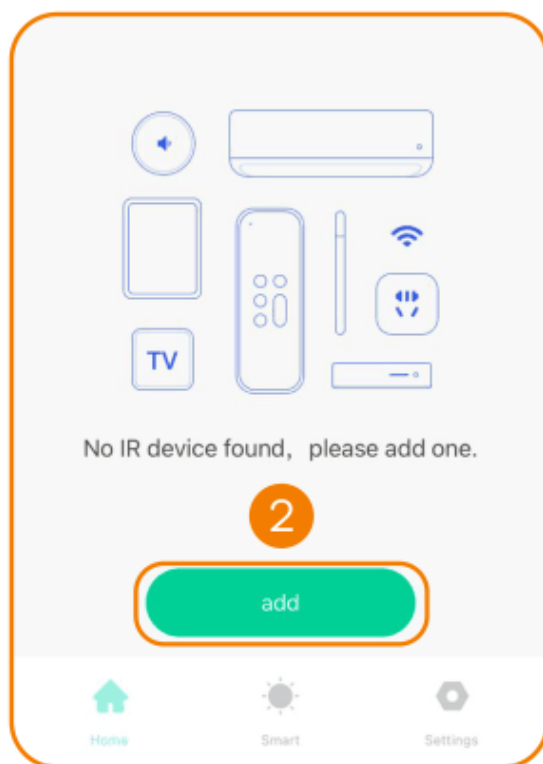
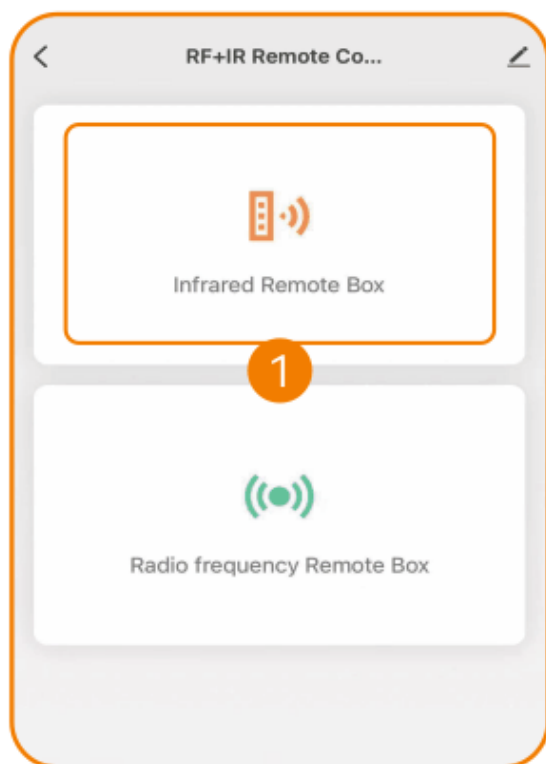

Adding an Unregistered Device :

1. If you don't find the device you're looking for, tap DIY to add a custom device.
2. If the device is still not in the DIY list, select "Other".
3. Tap + to add a custom device.

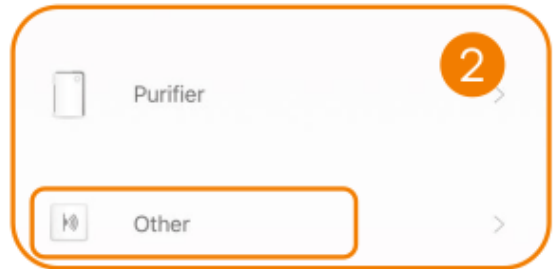
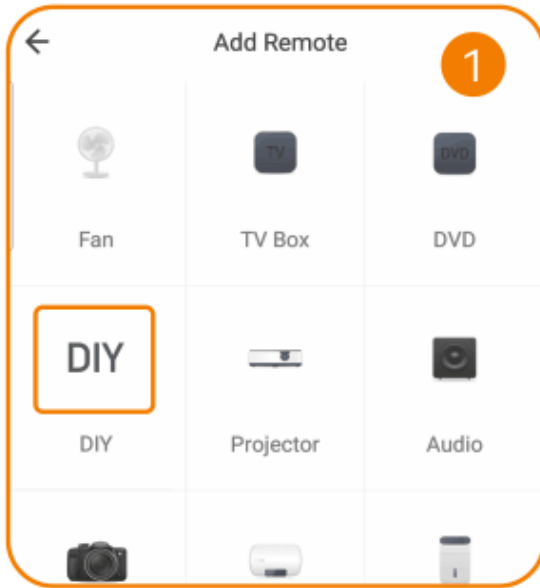

4. Point the remote at JETE-IR1+RF, then press one of the buttons on the remote that will be learned.
5. Name the button that has been learned.
6. Press finish.

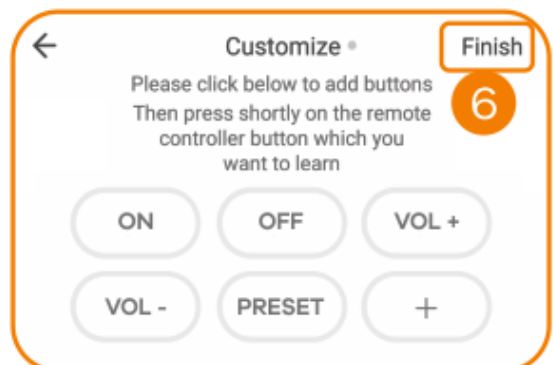
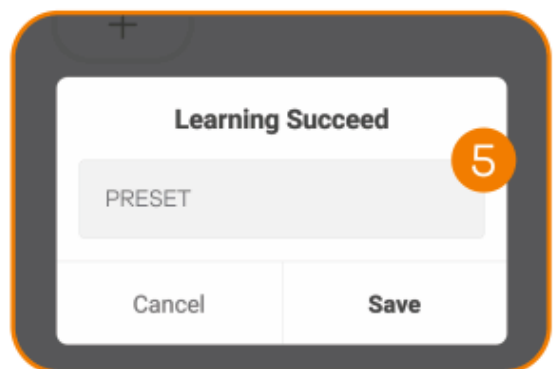
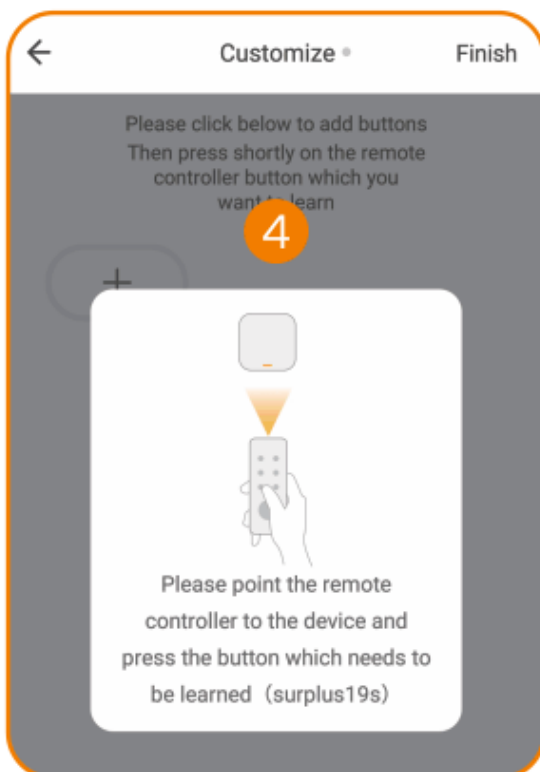

Adding RF Devices :

1. Select the Radio Frequency Remote Box device.
2. Press the "Add" icon.
3. Select the device you want to connect.
4. Press the icon that appears in the middle.
5. If the device does not react, press "Another One" then press the icon in the middle again.
6. If the device reacts, press "Can Control".

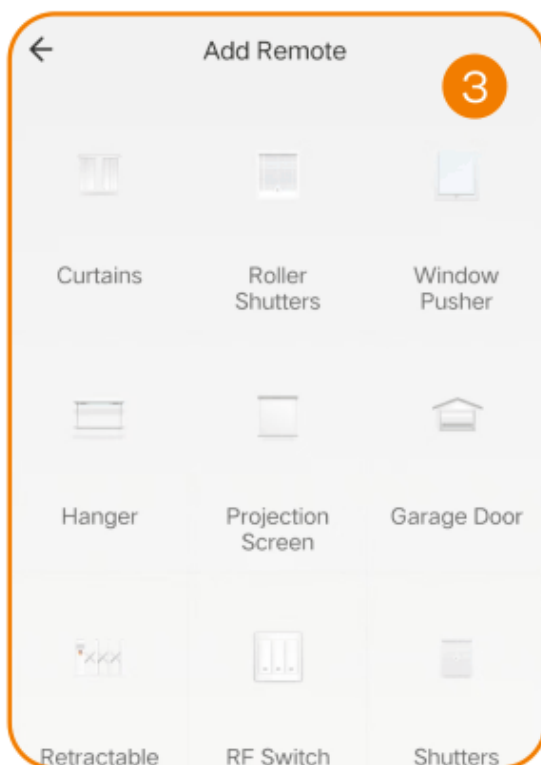
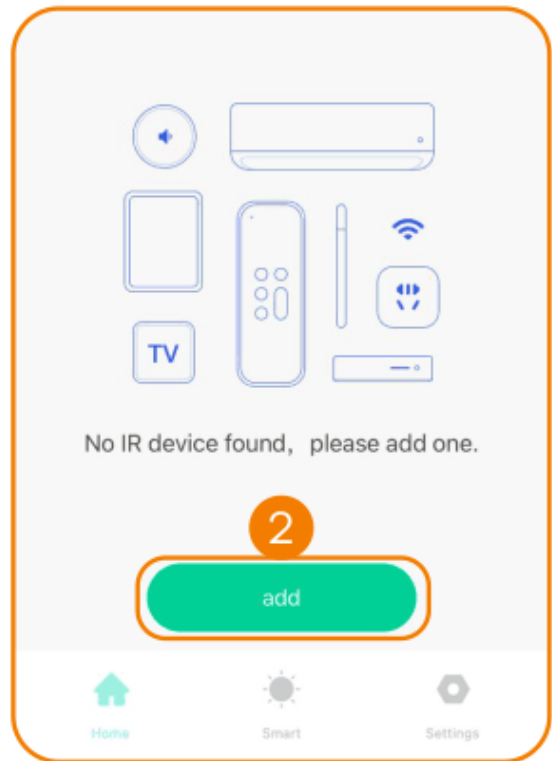
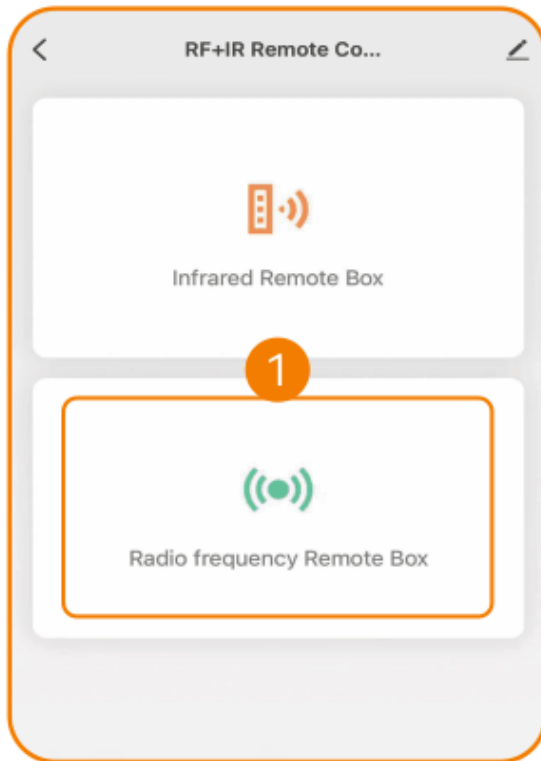

How to Reset Product :

Press the reset button for 5 seconds, the LED indicator will flash blue indicating that IR1+RF has been successfully reset.

Spesifikasi :

Size	: 75.8*20.7mm
Input	: DC 5V/1A
Infrared Frequency	: 38KHz
Infrared Range	: ≤12 M
WIFI Frequency	: 2.4GHz
Radio Frequency	: 433/315MHz

Maintenance :

Please read the following recommendations before using JETE

- Avoid exposing the device to water vapor or humid places. This can affect the internal circuit.
- Do not use cleaning solutions to clean the device.
- Do not expose the device to extreme heat or cold, as this can damage the device or change certain plastic parts.
- Avoid exposing the device to sharp objects, as this can cause scratches and damage.
- Do not disassemble or modify the device.
- Do not drop the device, as this can damage the circuitry.
- Always store the device at room temperature.

How to Warranty Claim JETE Product :

1. All warranty claims can be made at the list of Authorized Outlets listed on the warranty card.
2. Buyers can come to an authorized Outlet or contact Customer Service +62812-1739-3609 if they want to exchange the product online.
3. All expedition shipping costs / product postage are borne by the buyer.
4. When claiming the warranty, the buyer is **MANDATORY** to show the completeness of the warranty:
 - A purchase receipt that clearly states the name of the outlet and the date of the transaction.
 - The product must still be within the specified warranty period.
 - Warranty card that has been filled out.
 - Box / Packing Product.
5. Please inform the constraints / product damage that occurs to our staff.
6. **WARRANTY DOES NOT APPLY** if **USER DAMAGE** is found, namely:
 - **BROKEN, CRACKED, BURNED, DROPPED, MODIFIED BY YOURSELF, SUBMERGED IN WATER.**
7. If there are problems during warranty claims or other questions, please contact Customer Service +62812-1739-3609.

Terms and Conditions of Warranty :

1. This warranty is valid for 2 years for original JETE products.
2. This warranty is valid for the warranty period stated on the product packaging since the date of sale.
3. During the warranty period, the user is exempt from any replacement costs that may occur.
4. The user must show the warranty card and purchase receipt when applying for a warranty.
5. The warranty applies to functional damage:
 - Disfunction.
 - Audio not detected.
 - Indicator off.
 - Battery damage.
6. This warranty DOES NOT APPLY if:
 - PRODUCT IS BROKEN, CRACKED, BURNED, FALLEN,
 - MODIFIED YOURSELF, SOAKED IN WATER.
 - Supporting accessories such as: cables, adapters, etc.
 - Abnormal use, not stored properly, natural disasters, modified, or anything intentionally.
 - The product has been repaired by a third party.
 - The data is not filled in completely by the seller and buyer.
 - Damage caused by user error.
 - The product warranty period has expired.

**2 YEARS
WARRANTY**

NEW REPLACEMENT
FOR ANY FAULTS *T&C



Contact Us

JETE WARRANTY POINTS

