

JETE

**WARRANTY CARD and
USER MANUAL**

POWERBANK A15



e-Usermanual

IMPORTIR

PT. DORAN SUKSES INDONESIA

Jl. Lebak Jaya 2 Tengah No. 2, Surabaya

CUSTOMER SERVICE

 **081217393609**

 jete.id  [jeteindonesia](https://www.instagram.com/jeteindonesia)

 [jeteindonesia](https://www.facebook.com/jeteindonesia)  [jeteindonesia](https://www.twitter.com/jeteindonesia)

JETE

USER MANUAL

POWERBANK A15

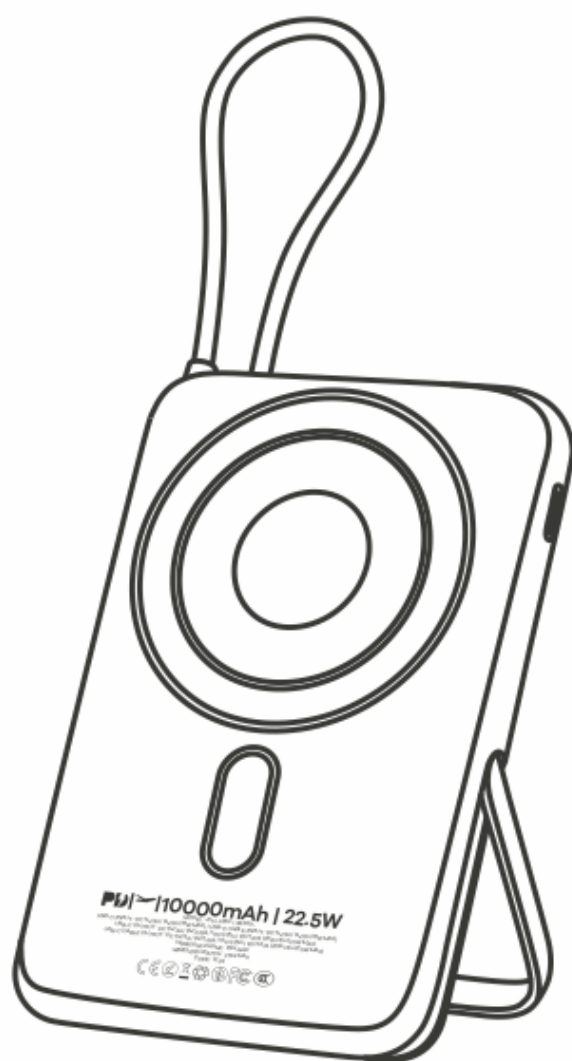

IMKG.2107.09.2020

Please read the instructions carefully
before using the product

Product Introduction :

Thank you for purchasing JETE products. For optimal and safe performance, it is expected to read the instructions carefully before using this product.

Content Package :



A15

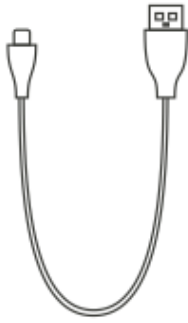

Charging Cable

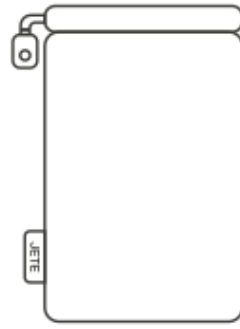

Pouch



User Manual

Description Structure Product :

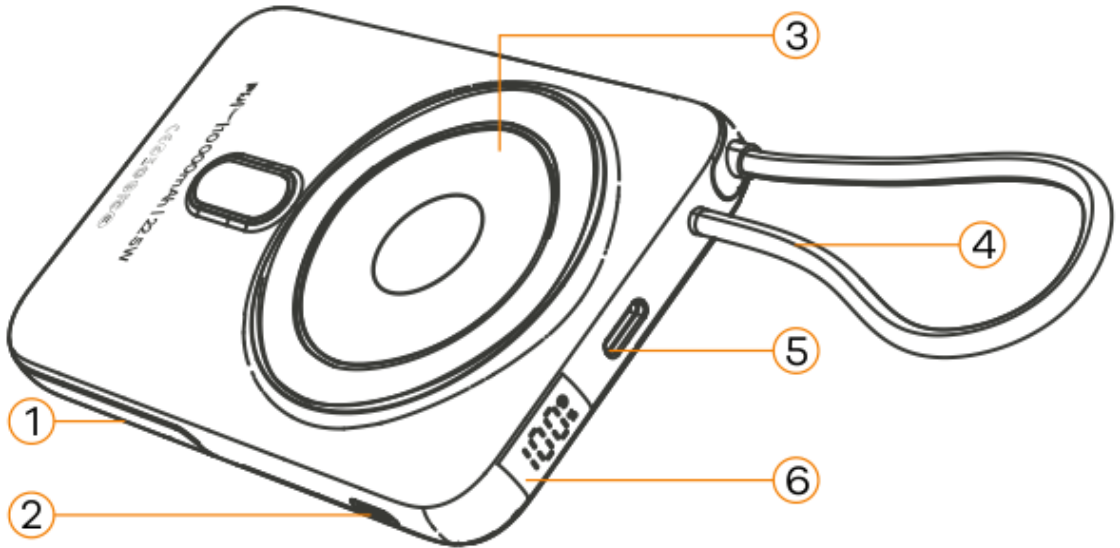

1. Kickstand
2. Power Button
3. Wireless Area

4. Type-C Cable
5. Port Type-C
6. Indicator LED

How to Use :

This product is indicated for digital devices with input.

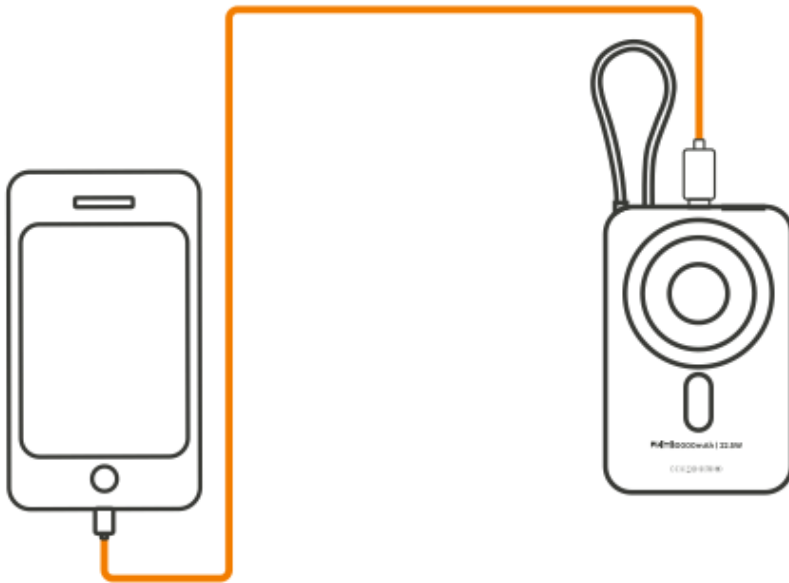

- Portable rechargeable powerbank according to powerbank specifications.
- Connect to mobile phones and various types of rechargeable devices.
- Has AUTO DETECT current technology.
- LED Indicator, to monitor the level of capacity available on the powerbank.

Note :

Powerbank charging time to full is 2 hours (fast charging).

Tips :

- Daily use can make the power bank in the best status.
- If not used for a long time, please store it at 50% capacity.
- If not used for a long time, please remember to charge it every 3 months.

Specification :

| | |
|--------------------|--|
| Model | : A15 |
| Capacity | : 10.000mAh 3.85V 38.5Wh |
| Material | : ABS + PC |
| USB-C Input | : 5V/3A 9V/2A (18W MAX) |
| USB-C Cable Input | : 5V/3A 9V/2A (18W MAX) |
| USB-C Output | : 5V/3A 9V/2.22A 10V/2.25A 12V/1.67A (20W PD+22.5W MAX) |
| USB-C Cable Output | : 5V/3A 9V/2.22A 10V/2.25A 12V/1.67A (20W PD+22.5W Max) |
| Wireless Phone | : 15W MAX |
| Wireless iWatch | : 2.5W MAX |
| Total Output | : 4 Output |
| Weight | : 195g |

Maintenance :

Please read the following recommendations before using JETE

- Avoid exposing the device to water vapor or humid places. This can affect the internal circuit.
- Do not use cleaning solutions to clean the device.
- Do not expose the device to extreme heat or cold, as this can damage the device or change certain plastic parts.
- Avoid exposing the device to sharp objects, as this can cause scratches and damage.
- Do not disassemble or modify the device.
- Do not drop the device, as this can damage the circuitry.
- Always store the device at room temperature.

How to Warranty Claim JETE Product :

1. All warranty claims can be made at the list of Authorized Outlets listed on the warranty card.
2. Buyers can come to an authorized Outlet or contact Customer Service +62812-1739-3609 if they want to exchange the product online.
3. All expedition shipping costs / product postage are borne by the buyer.
4. When claiming the warranty, the buyer is **MANDATORY** to show the completeness of the warranty:
 - A purchase receipt that clearly states the name of the outlet and the date of the transaction.
 - The product must still be within the specified warranty period.
 - Warranty card that has been filled out.
 - Box / Packing Product.
5. Please inform the constraints / product damage that occurs to our staff.
6. **WARRANTY DOES NOT APPLY** if **USER DAMAGE** is found, namely:
 - **BROKEN, CRACKED, BURNED, DROPPED, MODIFIED BY YOURSELF, SUBMERGED IN WATER.**
7. If there are problems during warranty claims or other questions, please contact Customer Service +62812-1739-3609.

Terms and Conditions of Warranty :

1. This warranty is valid for 2 years for original JETE products.
2. This warranty is valid for the warranty period stated on the product packaging since the date of sale.
3. During the warranty period, the user is exempt from any replacement costs that may occur.
4. The user must show the warranty card and purchase receipt when applying for a warranty.
5. The warranty applies to functional damage:
 - Disfunction.
 - Audio not detected.
 - Indicator off.
 - Battery damage.
6. This warranty DOES NOT APPLY if:
 - PRODUCT IS BROKEN, CRACKED, BURNED, FALLEN,
 - MODIFIED YOURSELF, SOAKED IN WATER.
 - Supporting accessories such as: cables, adapters, etc.
 - Abnormal use, not stored properly, natural disasters, modified, or anything intentionally.
 - The product has been repaired by a third party.
 - The data is not filled in completely by the seller and buyer.
 - Damage caused by user error.
 - The product warranty period has expired.

**2 YEARS
WARRANTY**

NEW REPLACEMENT
FOR ANY FAULTS *T&C



Contact Us

JETE WARRANTY POINTS

