

# JETE

## WARRANTY CARD and USER MANUAL

### WEBCAM W5



e-Usermanual

### IMPORTIR

## PT. DORAN SUKSES INDONESIA

Jl. Lebak Jaya 2 Tengah No. 2, Surabaya

### CUSTOMER SERVICE

 081217393609

 jete.id  jeteindonesia

 jeteindonesia  jeteindonesia

# JETE

## USER MANUAL

### WEBCAM W5

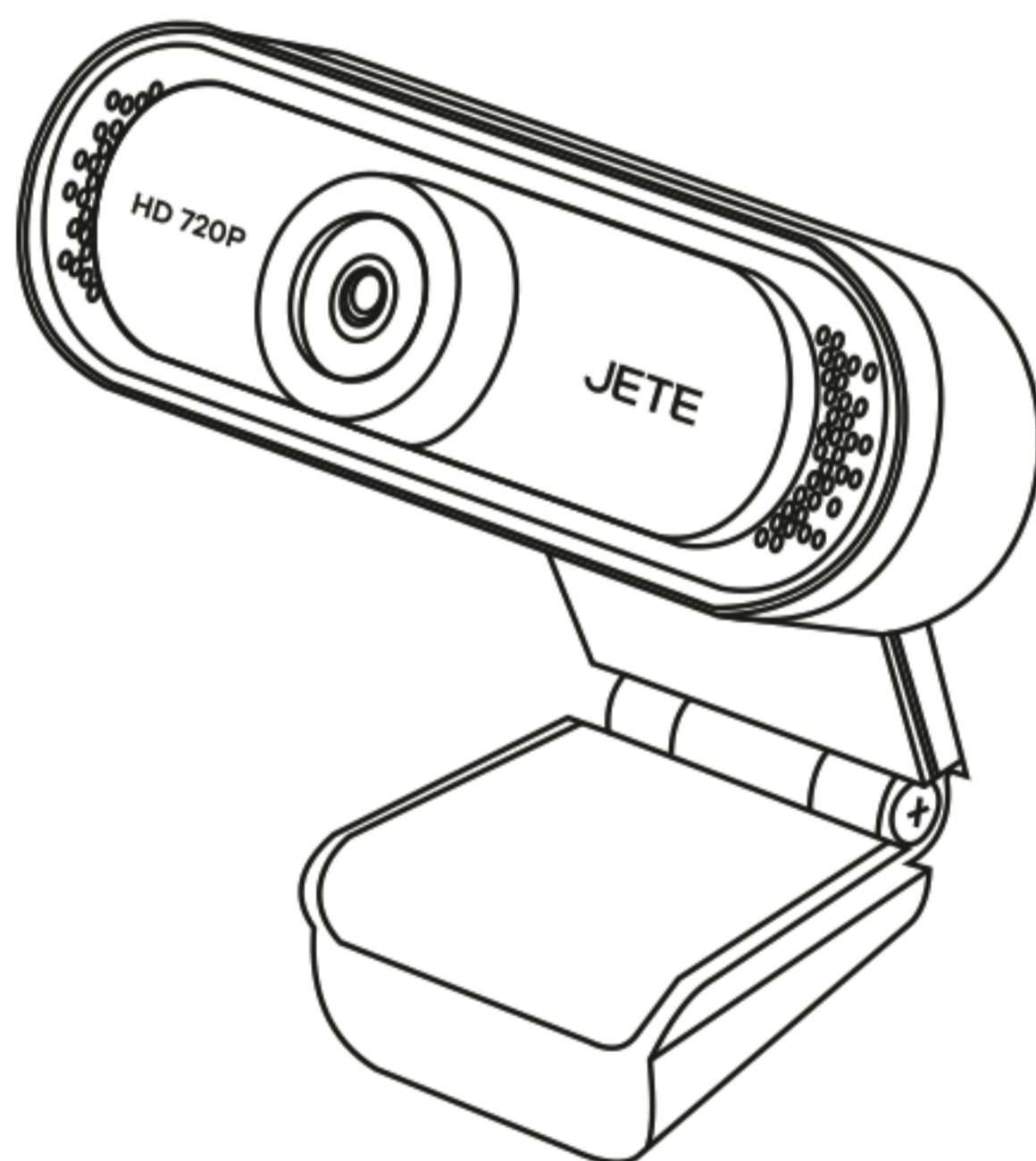

**IMKG.1573.10.2021**

Please read the instructions carefully  
before using the product.

## Introduction Product :

Thank you for purchasing JETE product for optimal and safe performance, expected to read the instructions well before running this product.

## Content Package :

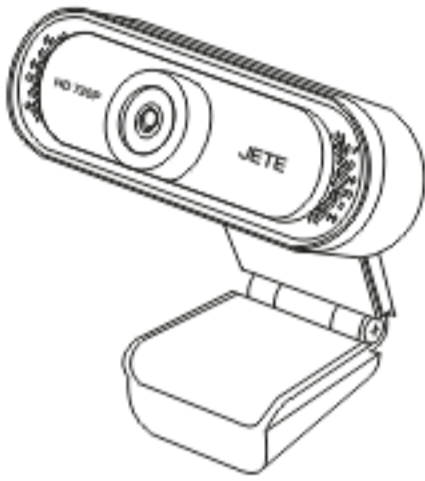

W5



User Manual

## Description Structure Product :

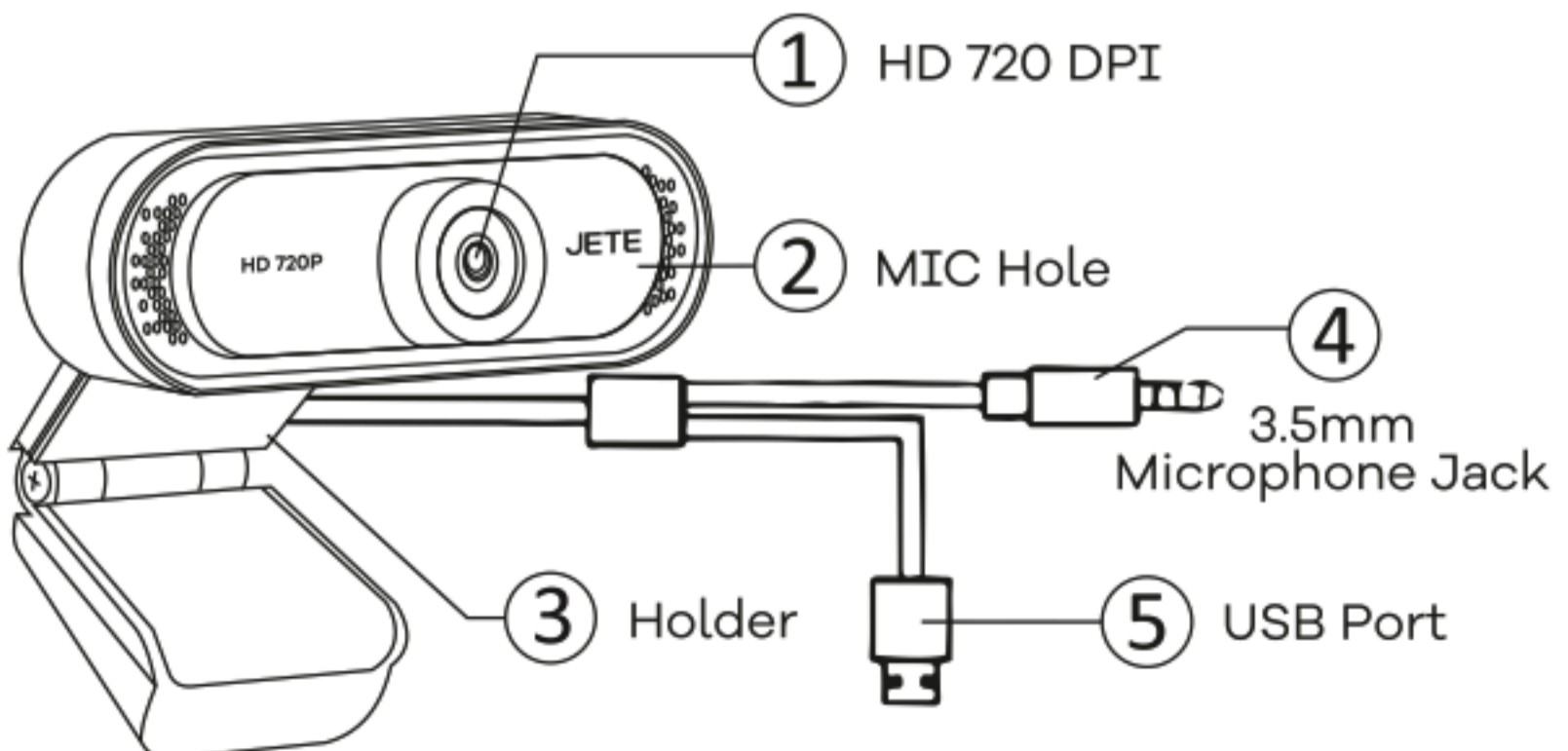

## How to Use :

- Connect the USB cable to the Laptop or Computer port.
- If you are using a MAC computer, you may need to purchase a USB to USB-C adapter so that the USB Webcam cable can be inserted into the USB port.
- Make sure the USB is plugged in properly

## Tips :

Regular use can keep the device in optimal condition

## Spesification :

Model	: W5
Piksel Physic	: 100W
Resolution	: HD 720 DPI
Wide Angle	: 120 degrees
Horizontal	
Microphone	: Built-in
Connection	: Plug and Play
Length Cable USB	: 120cm
Sensor	: 1/4" CMOS

## **Maintenance :**

Please read the following recommendations before using JETE

- Avoid exposing the device to water vapor or humid places. This can affect the internal circuit.
- Do not use cleaning solutions to clean the device.
- Do not expose the device to extreme heat or cold, as this can damage the device or change certain plastic parts.
- Avoid exposing the device to sharp objects, as this can cause scratches and damage.
- Do not disassemble or modify the device.
- Do not drop the device, as this can damage the circuitry.
- Always store the device at room temperature.

## How to Warranty Claim JETE Product :

1. All warranty claims can be made at the list of Authorized Outlets listed on the warranty card.
2. Buyers can come to an authorized Outlet or contact Customer Service +62812-1739-3609 if they want to exchange the product online.
3. All expedition shipping costs / product postage are borne by the buyer.
4. When claiming the warranty, the buyer is **MANDATORY** to show the completeness of the warranty:
  - A purchase receipt that clearly states the name of the outlet and the date of the transaction.
  - The product must still be within the specified warranty period.
  - Warranty card that has been filled out.
  - Box / Packing Product.
5. Please inform the constraints / product damage that occurs to our staff.
6. **WARRANTY DOES NOT APPLY** if **USER DAMAGE** is found, namely:
  - **BROKEN, CRACKED, BURNED, DROPPED, MODIFIED BY YOURSELF, SUBMERGED IN WATER.**
7. If there are problems during warranty claims or other questions, please contact Customer Service +62812-1739-3609

## Terms and Conditions of Warranty :

1. This warranty is valid for 2 years for original JETE products.
2. This warranty is valid for the warranty period stated on the product packaging since the date of sale.
3. During the warranty period, the user is exempt from any replacement costs that may occur.
4. The user must show the warranty card and purchase receipt when applying for a warranty.
5. The warranty applies to functional damage:
  - Disfunction.
  - Audio not detected.
  - Indicator off.
  - Battery damage.
6. This warranty DOES NOT APPLY if:
  - PRODUCT IS BROKEN, CRACKED, BURNED, FALLEN,
  - MODIFIED YOURSELF, SOAKED IN WATER.
  - Supporting accessories such as: cables, adapters, etc.
  - Abnormal use, not stored properly, natural disasters, modified, or anything intentionally.
  - The product has been repaired by a third party.
  - The data is not filled in completely by the seller and buyer.
  - Damage caused by user error.
  - The product warranty period has expired.

**2 YEARS  
WARRANTY**

NEW REPLACEMENT  
FOR ANY FAULTS \*T&C



Contact Us

## **JETE WARRANTY POINTS**

