

JETE

**WARRANTY CARD and
USER MANUAL**

HEADSET OPENEAR 2



e-Usermanual

IMPORTIR

PT. DORAN SUKSES INDONESIA

Jl. Lebak Jaya 2 Tengah No. 2, Surabaya

CUSTOMER SERVICE

 **081217393609**

 jete.id  [jeteindonesia](https://www.instagram.com/jeteindonesia)

 [jeteindonesia](https://www.facebook.com/jeteindonesia)  [jeteindonesia](https://www.twitter.com/jeteindonesia)

JETE

USER MANUAL

HEADSET OPENEAR 2



Please read the instructions carefully
before using the product.

Product Introduction :

Thank you for purchasing JETE products. For optimal and safe performance, please read the instructions carefully before using this product.

Package Content :

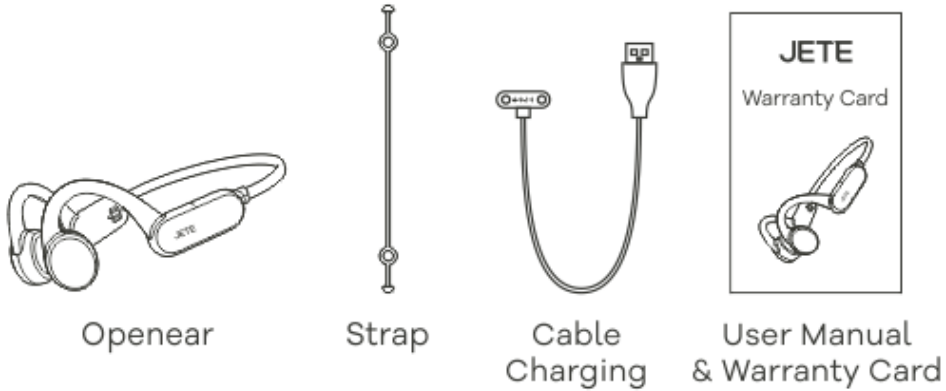

Description Structure Product :

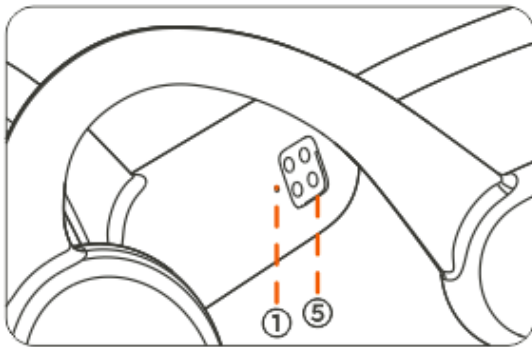

1. Light Indicator
2. MFB
3. Volume - / Next Song

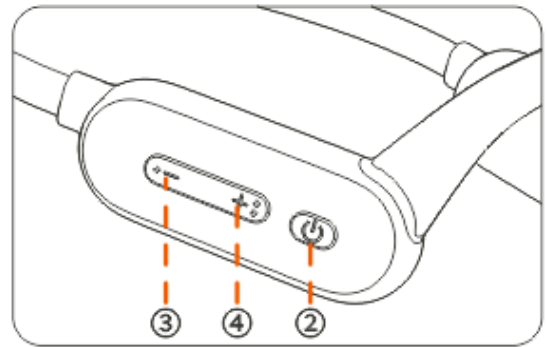

4. Volume + / Previous Song
5. Charging Port

How to use :

How to Turn On the Headset :

Press the power button for 3 seconds LED blinks blue and red and sound is heard indicating the headset is successfully turned on.

JETE OPENEAR Have 2 Mode :

- Normal mode : normal bluetooth mode in general
- TF mode : Playback mode using internal memory on openear device.

How to Turn Off the Headset :

Press the MFB for 3 seconds, and you will hear the sound "Power OFF" and indicating the headset was successfully turned off.

How to Change Mode :

Press the MFB button 2 times quickly, and you will hear "TF MODE/BLUETOOTH MODE" when the mode has changed.

How to Connect the Device with Headset :

Turn on the bluetooth menu and search for "JETE-OPENEAR" click 'Connect" then there will be a sound that indicates the headset is connected to bluetooth on your cellphone.

How to Answer Incoming Call :

- Press 1 times at the MFB button to answer the call

How to End a Call :

- Press 1 times at the MFB button to end the call

How to Reject a Call :

- Press 2 seconds at the power button to reject the call

How to Previous Song :

- Press 2 Seconds at the – button for the previous song

How to Next Song :

- Press 2 Seconds at the + button for the next song

How to Play/Pause :

- Press 1 times at the MFB button for Play/pause song

How to Increase Volume :

- Press 1 times at the + Button for increase volume

How to Decrease Volume :

- Press 1 times at the - Button for increase volume

How to Active Feature Voice Assistant :

- Press 2 seconds at the MFB button active voice assistance at your handphone

How to Factory Reset

- Press the MFB for 10 seconds to restore to factory settings

How to Tell if the Battery is Low :

- The LED will flash green every 30 seconds when the battery is 10% low and a "battery low" sound will be heard indicating the battery must be charged.

How to Charge :

A 5V DC charging adapter is recommended.

- The red color of the LED indicates that the battery is charging. LED will turn blue when charging is complete

How to Save Music :

- Connect USB to PC/Laptop with device , and send music to device.

Spesification :

Model	: OPENEAR 2
Bluetooth	: V5.3
Type	: Open-ear Headset Sport
Wireless Range	: 10 m (Without Obstacles)
Mic Sensitivity	: -42dB
Input Voltage/Current	: DC 5V/1A
Impedance	: $22\Omega \pm 15\%$ (at 800 HZ)
Sensitivity	: $8\Omega \pm 15\%$
Speaker Frequency	: 20 Hz ~ 20 Khz
Playtime	: 6 Hour (60 Volume)
Standby Time	: 220 Hour
Charging Time	: 2 Hour
Battery Capacity	: 230 mAh Polymer Battery
Internal Memory	: 8 gb

Maintenance :

Please read the following recommendations before using JETE

- Avoid exposing the device to water vapor or humid places. This can affect the internal circuit.
- Do not use cleaning solutions to clean the device.
- Do not expose the device to extreme heat or cold, as this can damage the device or change certain plastic parts.
- Avoid exposing the device to sharp objects, as this can cause scratches and damage.
- Do not disassemble or modify the device.
- Do not drop the device, as this can damage the circuitry.
- Always store the device at room temperature.

How to Warranty Claim JETE Product :

1. All warranty claims can be made at the list of Authorized Outlets listed on the warranty card.
2. Buyers can come to an authorized Outlet or contact Customer Service +62812-1739-3609 if they want to exchange the product online.
3. All expedition shipping costs / product postage are borne by the buyer.
4. When claiming the warranty, the buyer is **MANDATORY** to show the completeness of the warranty:
 - A purchase receipt that clearly states the name of the outlet and the date of the transaction.
 - The product must still be within the specified warranty period.
 - Warranty card that has been filled out.
 - Box / Packing Product.
5. Please inform the constraints / product damage that occurs to our staff.
6. **WARRANTY DOES NOT APPLY** if **USER DAMAGE** is found, namely:
 - **BROKEN, CRACKED, BURNED, DROPPED, MODIFIED BY YOURSELF, SUBMERGED IN WATER.**
7. If there are problems during warranty claims or other questions, please contact Customer Service +62812-1739-3609

Terms and Conditions of Warranty :

1. This warranty is valid for 2 years for original JETE products.
2. This warranty is valid for the warranty period stated on the product packaging since the date of sale.
3. During the warranty period, the user is exempt from any replacement costs that may occur.
4. The user must show the warranty card and purchase receipt when applying for a warranty.
5. The warranty applies to functional damage:
 - Disfunction.
 - Audio not detected.
 - Indicator off.
 - Battery damage.
6. This warranty DOES NOT APPLY if:
 - PRODUCT IS BROKEN, CRACKED, BURNED, FALLEN,
 - MODIFIED YOURSELF, SOAKED IN WATER.
 - Supporting accessories such as: cables, adapters, etc.
 - Abnormal use, not stored properly, natural disasters, modified, or anything intentionally.
 - The product has been repaired by a third party.
 - The data is not filled in completely by the seller and buyer.
 - Damage caused by user error.
 - The product warranty period has expired.

**2 YEARS
WARRANTY**

NEW REPLACEMENT
FOR ANY FAULTS *T&C



Contact Us

JETE WARRANTY POINTS

